

HENRY

Hydraulic Engineering Repository

Ein Service der Bundesanstalt für Wasserbau

Conference Paper, Published Version

Sun, Hongbing; Koch, Manfred

Under- versus Overestimation of Aquifer Hydraulic Conductivity from Slug Tests

Zur Verfügung gestellt in Kooperation mit/Provided in Cooperation with:
Kuratorium für Forschung im Küsteningenieurwesen (KFKI)

Verfügbar unter/Available at: <https://hdl.handle.net/20.500.11970/99448>

Vorgeschlagene Zitierweise/Suggested citation:

Sun, Hongbing; Koch, Manfred (2014): Under- versus Overestimation of Aquifer Hydraulic Conductivity from Slug Tests. In: Lehfeldt, Rainer; Kopmann, Rebekka (Hg.): ICHE 2014. Proceedings of the 11th International Conference on Hydrosience & Engineering. Karlsruhe: Bundesanstalt für Wasserbau. S. 327-336.

Standardnutzungsbedingungen/Terms of Use:

Die Dokumente in HENRY stehen unter der Creative Commons Lizenz CC BY 4.0, sofern keine abweichenden Nutzungsbedingungen getroffen wurden. Damit ist sowohl die kommerzielle Nutzung als auch das Teilen, die Weiterbearbeitung und Speicherung erlaubt. Das Verwenden und das Bearbeiten stehen unter der Bedingung der Namensnennung. Im Einzelfall kann eine restriktivere Lizenz gelten; dann gelten abweichend von den obigen Nutzungsbedingungen die in der dort genannten Lizenz gewährten Nutzungsrechte.

Documents in HENRY are made available under the Creative Commons License CC BY 4.0, if no other license is applicable. Under CC BY 4.0 commercial use and sharing, remixing, transforming, and building upon the material of the work is permitted. In some cases a different, more restrictive license may apply; if applicable the terms of the restrictive license will be binding.



Under- versus Overestimation of Aquifer Hydraulic Conductivity from Slug Tests

H. Sun

Department of Geological, Environmental, and Marine Sciences, Rider University, Lawrenceville, New Jersey, USA

M. Koch

Department of Geotechnology and Geohydraulics University of Kassel, Kassel, Germany

ABSTRACT: Extensive examinations of hydraulic conductivities from calculated, simulated, and actual field slug and pumping tests reveal that the well-known Hvorslev- and Bouwer and Rice- slug test methods can underestimate the hydraulic conductivity K in such a test due to the lack of consideration for the drag from unsaturated flow and use of “late straight-line segment” in a $H(t)/H_0$ - semi-log plot of a slug test. This is in contrast to the claim of overestimation of K that the classical theory underlying these slug-test methods - which omits the effects of the aquifer's storativity, and which may, so, be a particularly problem in an unconfined aquifer, predicts. Numerical solutions of the exact equations describing a slug test have been carried out which corroborate this overestimation of K in an unconfined aquifer, but only for low conductivity values ($K < 1$ m/day), and when the “first straight line segment” of the semi-log ($H(t)/H_0$) vs. time- plot is used in the Hvorslev- or the Bouwer and Rice analyses. Although, theoretically, overestimation also exists for slug tests conducted in a high-conductivity aquifer, this is partly masked by the absence of early recordings of hydraulic head changes in the observation well, as well as a mixture of saturated and unsaturated flow in a slug well after slug injection. The “inadvertent” utilization of an “inherent” “late straight line-segment” in the semi-log $H(t)/H_0$ plot often results, in fact, in an underestimation of conductivities in a high-conductivity aquifer. Hydraulic conductivity estimation from both our computer simulations and field studies, where the results of slug- and pumping tests are compared, supports the conclusion of the underestimation of the hydraulic conductivity in a slug test for a moderate- to high-conductivity aquifer. Therefore, it is suggested here that for estimating the hydraulic conductivity from a slug test, “a late straight line-segment” - correction in the log ($H(t)/H_0$)- plot may only be needed in a low-conductivity aquifer, whereas in a moderate- to high-conductivity unconfined aquifer, the early or “first possible straight line-segment” in the log $H(t)/H_0$ - plot of a slug test is recommended, instead of the traditionally used “late straight line segment”.

Keywords: Slug test, Hvorslev, Bouwer and Rice, Hydraulic conductivity

1 INTRODUCTION

Hydraulic conductivity is one of the most important hydrological parameters that are required in a groundwater study. Slug tests have been considered as one popular and economical means for obtaining this parameter. Depending on the nature of the aquifer, i.e. whether it is confined or unconfined, different methods with different properties have been developed for the estimation of the hydraulic conductivity from a slug test. The most eminent ones in use nowadays are the Cooper-Bredehoeft-Papadopoulos (CBP) method (Cooper *et al.*, 1967), the Hvorslev- method (Hvorslev, 1951) and the Bouwer and Rice (BR)-method (Bouwer and Rice, 1972), though the KGS model (Butler, 1998) is also gaining popularity.

For a confined aquifer, the Cooper-Bredehoeft-Papadopoulos (CBP) method (Cooper *et al.*, 1967) is considered a better measure of the field conductivity than the Hvorslev- and BR- methods (Hvorslev, 1951), due to the inclusion of the aquifer storativity in the former (Hyder and Butler, 1995). The CBP-slug test method uses a semi-log plot of the ratio $H(t)/H_0$ vs. time - where $H(t)/H_0$ is the ratio of current to initial hydraulic head after the beginning of the slug injection - to match the theoretical curves developed by Cooper *et al.* (1967).

On the other hand, for an unconfined aquifer, the Hvorslev method is still one of the most widely used estimation method today, due to its simplicity (Butler, 1998; Campbell *et al.*, 1990; Fetter, 2001). A modification of the Hvorslev method which considers the effect of partial penetrating conditions and a comprehensive handling of the effective well radius is the Bouwer and Rice (BR) method (Bouwer and Rice, 1972). This technique is considered an improved alternative of the Hvorslev method for an unconfined aquifer (Todd and Mays, 2005).

The mathematical validity of the CBP-, the Hvorslev- and the BR- method have been established previously by various researchers (Chirlin, 1989; Chapuis, 1998). In recent years, many studies were also conducted to evaluate the sensitivities of the conductivity estimates to the variation of several other important hydraulic parameters, including the storativity and the vertical anisotropy (Bohling and Butler, 2001; Hyder and Butler, 1995; McElwee *et al.*, 1995a; b). Based on these and other field studies, many valuable suggestions have been recommended for improving the procedures of data collection, as well as the analyses of slug tests. Additional valuable methods were derived for slug tests as well (Butler, 1998; Dagan, 1978; Zurbuchen, et al., 2002).

Despite the mentioned improvements of the Hvorslev- and of the BR- slug test method, many issues regarding the accuracy of the conductivity estimates obtained by these techniques still persist in practical applications. Thus, on one hand, both the Hvorslev- and the BR-methods are thought to overestimate the conductivity of a slug test, if only the early straight-line segment of the $H(t)/H_0$ - plot is used (Hyder and Butler, 1995). Therefore, Bouwer (1989) suggested to use “a late straight-line segment” of the $H(t)/H_0$ -plot, in order to alleviate the impact of a high conductivity gravel/sand pack on the overall conductivity estimation, as double straight-line segments may exist for such a case. Butler (1996), subsequently, defined this late straight line segment to be in the “ $H(t)/H_0 = 0.15$ to 0.3 range” and showed that doing so, can reduce the overestimation of the hydraulic conductivity, particularly, in a low-conductivity aquifer.

On the other hand, it is also reported that conductivity estimates from slug tests are generally smaller than those from pumping tests. Some of these underestimations of K from a slug test might be explained as due to the blockage of the “well-skin” effect for water flow, as suggested by previous researchers (Butler, 1996). However, the underestimation of conductivity by an ill-defined “well skin” effect cannot explain the generally large differences between conductivities from slug tests and the well pumping tests.

This paper attempts to use the flow analog between the unconfined pumping test and a slug test, where early drawdown, late drawdown and delayed yield is used separately to estimate the conductivity and yield of an aquifer and a scale factor between the conductivity from a laboratory measurement and field tests to examine the causes for the over- and, in particular, the underestimation of the conductivity from a slug test. This will be done through numerical simulations of groundwater flow under slug test conditions, as well as analyses of field slug tests under various scenarios. The advantage of utilizing simulated slug tests, in addition to field data, is that the actual hydraulic conductivity and storativity are given, so that the relationships among estimated and true values of the conductivity, and of the storativity, can be visualized and quantified. The final goal is to provide a better understanding on the causes of the large difference between hydraulic conductivity obtained from slug tests and pumping tests, particularly, in a moderately high- to high-conductivity aquifer.

2 THEORY OF SLUG TESTS

Assuming a homogeneous, isotropic horizontal aquifer and ignoring the vertical flow, the CBP-, Hvorslev- and BR-slug test solutions can be obtained by solving the following 2D- transient groundwater flow equation in radial (polar) coordinates with axial symmetry under appropriate initial and boundary conditions (Neuman and Witherspoon, 1969):

$$\frac{\partial^2 h}{\partial r^2} + \frac{1}{r} \frac{\partial h}{\partial r} = \frac{S_s \partial h}{K \partial t} \quad (1)$$

where h is the hydraulic head, r is the radial distance from the center of the well (Figure 1), t is the time, S_s is the specific storage (equal to zero for the Hvorslev and BR method), and K is the hydraulic conductivity. From the principle of conservation of mass, the slug-induced water flowing out of the fully screened borehole equals the water flowing into the aquifer, i.e.

$$2\pi r_w K \frac{\partial h(r_w, t)}{\partial r} = \frac{\pi r_c^2}{b} \frac{\partial H(t)}{\partial t} \quad (2)$$

where r_w is the effective radius of the well screen, r_c is the radius of the well case, b is the thickness of the aquifer, and $H(t)$ is the level of water in the well at time t .

For the CBP-method, the initial conditions are:

$$h(r, 0)=0, \quad r_w < r < \infty; \quad H(0)=H_0 \quad (3)$$

where H_0 is the height of the initial slug. The boundary conditions are:

$$h(r_w, t) = H(t); \quad h(\infty, t) = 0 \quad (4)$$

For both the Hvorslev- and the BR-method, the storativity $S_s=0$ in Eq. (1). The initial conditions are the same as in the CBP-method, however, the boundary conditions are slightly different:

$$h(r_w, t) = H(t), \quad h(R_e, t) = 0 \quad (5)$$

where R_e is the empirical effective radius of the slug test which is usually approximated by the length of the well screen or by $200 \cdot r_w$ (Fetter, 2001; Butler, 1997).

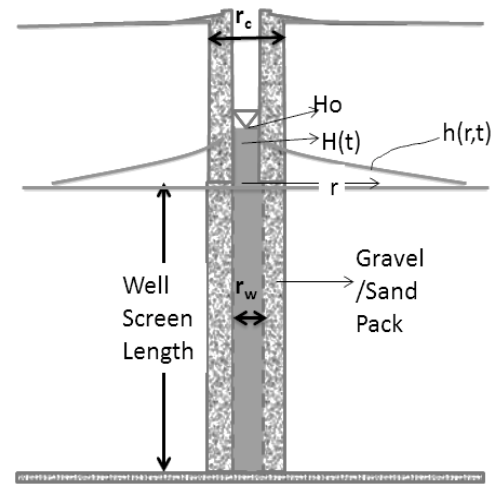

Figure 1. Slug test scheme showing the positions of parameters and gravel/sand pack.

2.1 CBP Solution

For a confined aquifer, the analytical solution of the governing equation (1) $H(t)$ within the well was given in the forms of Bessel functions by Cooper et al.(1967). Assuming an instantaneous slug injection, transmissivity T and storativity S are estimated from the semi-log plot of the measured $H(t)/H_0$ vs. time of a slug test from Copper *et al.* (1967)'s solution, by the following formula,

$$T = \frac{r_c^2}{t}, \quad S = \frac{r_c^2 \alpha}{r_w^2} \quad (6)$$

where α is the dimensionless storage parameter obtained from Cooper et al (1967)'s type curves and t is the time. Other parameters have the same meaning as above.

Since the CBP-solution, unlike that of the other two slug test solutions, is based on the complete transient groundwater flow equation (1), it will also later be used as a reference solution for those of the Hvorslev- and the BR-method.

2.2 Hvorslev Solution

The Hvorslev- slug test solution is obtained using Thiem's quasi-steady state approach, i.e. setting the storativity $S_s=0$. in Eq. (1.) and solving Eqs. (1-5). Using the screen length as the effective well radius, the equation for the hydraulic conductivity K is then given as (Chirplin, 1989; Hvorslev, 1957):

$$K = \frac{r_c^2 \ln\left(\frac{L_e}{r_w}\right)}{2L_e t_{0.37}} \quad (7)$$

where r_c and r_w have the same meaning as above, L_e is the effective screen length, and $t_{0.37}$ is the time, when the ratio of the hydraulic heads $H(t)/H_0$ reaches 0.37.

2.3 Bouwer and Rice (BR) Solution

Similar to the Hvorslev -solution, the BR- slug test solution is also based on the assumption $S_s=0$. in the equation group (1-5). Again, using a Thiem's-formulation, the following equation for the hydraulic conductivity is finally obtained [7]:

$$K = \frac{r_c^2 \ln\left(\frac{R_e}{r_w}\right)}{2L_e t} \ln \left[\frac{H_0}{H} \right] \quad (8)$$

where R_e is the effective radial distance over which the head is dissipated, and the other parameters are as discussed. Note that Eq. (8) is practically identical to Eq. (7) of the Hvorslev method, when one takes t as the time $t_{0.37}$ it takes for $\log(H(t)/H_0)$ to change over one cycle, i.e. $H(t)/H_0 = 1/e = 0.37$. However, the correction of the effective radius R_e in the BR-method is slightly more complicated, because the effective

screen length L_e is not directly used as the effective radius R_e . In fact, the $\ln(R_e/r_w)$ in Eq. (8) has to be obtained from calculated curves provided by Bouwer and Rice (1976) and which are also adopted in most hydrogeology textbooks (Fetter, 2001; Todd and Mays, 2005).

It should be noted again that, because both the Hvorslev - and the BR-method neglect the specific storage ($S_s=0$) - the presence of the latter would induce a flow delay in the initial stage of the slug test - , the solution of the equation group (1-5) with $S_s=0$. exaggerates the flow rate of the system. Therefore, equations (7) and (8) inherently overestimate the hydraulic conductivity of the aquifer, when storage plays a significant role, which is usually the case for an unconfined aquifer, for which the specific yield is high, i.e. usually ranging from 0.1 to 0.4.

3 SIMULATIONS OF SLUG TESTS WITH MODFLOW

The USGS MODFLOW groundwater flow model solves the 3D groundwater flow equation by means of a finite difference method under appropriate boundary and initial conditions (McDonald and Harbaugh, 1983). This most widely used groundwater flow model has been verified and applied to umpteen of confined and unconfined aquifers across the world (Todd and Mays, 2005).

For this study, MODFLOW is adapted to solve the 2D- radial symmetric form (Eq. 1) of the groundwater flow equation in a rectangular domain around the slug-test well. The size of the model region has been set as 100x100 meters, which should be large enough, so that boundary conditions will not affect the area of influence of the slug test in the interior of the model domain. For the former, Neumann no-flow boundary conditions have been specified at the four model sides. Each cell has a size of 1x1 meter. This initial 1x1 meter center cell of the domain has then been divided into a cluster of 10000 1 cm x 1 cm (centimeter) cells. Out of this cluster, 78 clustered 1x1 cm cells have been selected as the well cells proper, to form a roughly round area of 78 cm² which is also approximately the area of a common slug well with a radius of 5 cm (~2 inches). The well is assumed to fully penetrate the saturated portion of the aquifer. Following Chirlin (1989) and Bohling and Butler's practices (2001), the storativity or the specific yield in the well cells have been set as 1 to illustrate the concept that the water drained as a consequence of a unit head drop in a slug well equals the volume of that height of water in the well itself, which mimics the situation that no solid grains are present in the well, i.e. the porosity is one. For simplification, gravel packing around the well screen has not been considered in the slug test simulations and the well screen extends over the full thickness of aquifer, i.e. fully penetrating well-conditions are assumed in the slug tests. The thickness of the aquifer is 100 meters and the screen length used is 80 meters in most situations discussed in the following sections, unless specified otherwise.

4 EFFECTS OF SLUG SIZE AND DURATION OF SLUG INJECTION ON ESTIMATED CONDUCTIVITIES

One interesting discovery from the simulation results is that the slug sizes do not have a measurable effect on the values of the estimated hydraulic conductivity, if the early straight line segment of the $\log(H(t)/H_0)$ - plot is used and either the Hvorslev-, or the BR- method is used (Figure 3). Because there are no gravel or sand packs around the well screens and, so, no skin effects in the simulated slug wells, the first straight-line segment of $\log(H(t)/H_0)$ reflects the instantaneous discharge of the water from the slug well into the aquifer storages. The first straight-line segments of all different sizes of slug injections have an identical slope, so that the critical time $t_{0.37}$ is identical for all slug sizes. However, the first straight lines break off into a curve at a different time for different slug sizes, such that the "early drawdown" ends earlier for smaller than for larger slugs. This is consistent with the common observations of "early and late drawdown and delayed yield" for the unsteady radial flow in an unconfined aquifer in a pumping well (Todd and Mays 2005). This "early drawdown", which produces the first straight- line segment, may reflect the actual aquifer conductivity. As will be discussed later, for the 30 slug wells in the Texas study site, for which the slug sizes are available (Houston and Braun, 2004), statistically significant correlations (95% confidence) between the slug sizes and estimated conductivities were neither observed, corroborating our simulation findings here.

On the other hand, the time duration of the slug injections affects the conductivity estimation by the Hvorslev- and BR- methods, particularly, for the unconfined aquifers, even if the first straight-line segments are used (Figure 3). Thus, whereas for a confined aquifer, the differences in $t_{0.37}$ for varied dura-

tions of the slug injections are minor, the situation is quite more worrisome for an unconfined aquifer. For the latter, the duration of the slug injection has a significant effect on the estimated value of the conductivity, such that the longer the duration, the smaller the conductivity. Figure 3 shows clearly that this effect is more apparent in a high-conductivity unconfined aquifer. In a practical field study, injections of slugs can rarely be conducted within a 0.001-second period, as done here in the simulations - even with a pneumatic pressure injection method (Leap, 1984; Butler *et al.*, 1996) - and are usually longer.

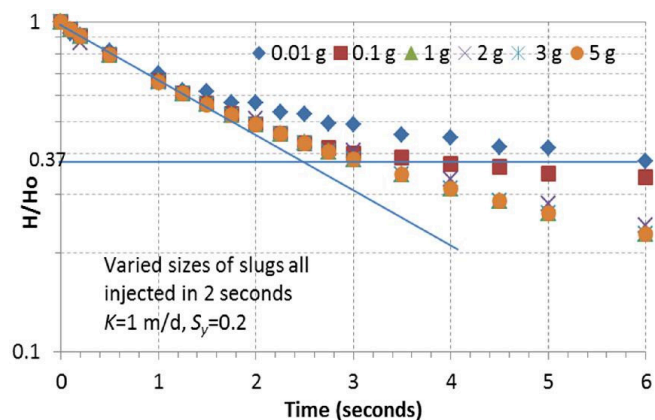

Figure 2. Semi-log plot of H/H_o vs. *time* of simulated slug tests with varied slug sizes injected (in gallons g as indicated) within 2 seconds, for a case with conductivity $K = 1 \text{ m/d}$ and storativity $S_y = 0.2$.

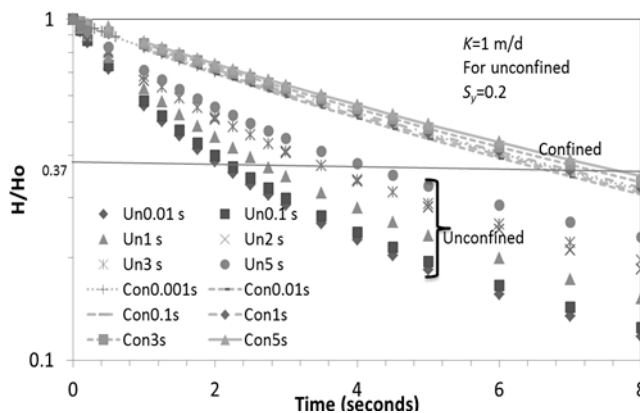

Figure 3. Semi-log plot of $\log(H/H_o)$ vs. *time* of simulated slug tests with varied time durations of slug injection. “Un” stands for an unconfined, “Con” for a confined aquifer; number s is the duration of injection in seconds.

5 OVER- AND UNDERESTIMATION OF CONDUCTIVITIES BASED ON SIMULATED DATA

Because the hydraulic conductivities used in the simulations are known, the finally estimated values using the CBP-, the Hvorslev-, and the BR- methods can be compared directly with the former.

5.1 Estimated Conductivities from the CBP Method

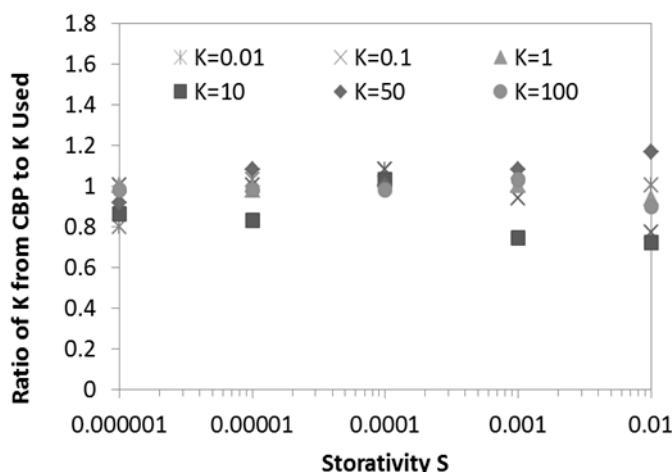

Figure 4. Ratios of estimated conductivities K (in m/d) from CBP curve fitting to actual conductivities used in the simulated slug tests of confined aquifers as a function of the storativity S .

Following the traditional procedure of the CBP-method for estimation of the conductivity in a confined aquifer, the semi-log plots of $H(t)/H_o$ vs. $\log(\text{time})$ extracted from the simulated slug tests have been manually fitted to the CBP curves. The estimated conductivity values are within $\pm 20\%$ of the assumed input conductivities (Figure 4). Part of these 20%- variations might be due to the inconsistency in the manual curve fittings and the small time steps used in the MODFLOW simulation for extracting multiple hydraulic heads within 0.1 seconds after a slug injection. The CBP method is generally regarded as a

relatively reliable method for estimating conductivities and is considered better than the Hvorslev method in a confined aquifer (Chirlin, 1989; Butler *et al.*, 1994; Chapuis, 1998; Hyder *et al.*, 1994).

5.2 Estimated Conductivities from the Hvorslev, and Bouwer and Rice Methods

In a confined aquifer, overestimation of the conductivity by the Hvorslev method is, unlike for an unconfined aquifer, relatively small, because of the low storativity of 10^{-6} to 10^{-3} in the former, regardless of whether the first or a late straight-line segment is used (Figures 3 and 4).

In an unconfined aquifer, however, theoretically, both the Hvorslev- and the BR- method overestimate the aquifer conductivity, due to their inherent omission of the storativity, i.e. the specific yield S_y , in their solutions. This can be clearly seen from Figure 5, where the ratios of estimated vs. actual conductivities are plotted as a function of the specific yield S_y for the example case of a 100-meter-thick aquifer and a screen length of 80 meter. As expected by theory, this overestimation of K increases with increasing S_y , and is particularly high for small values of K . This result gives some support for the common practice of using a "late straight-line segment" in the $\log(H(t)/H_0)$ - plot - as suggested by Bouwer (1989) to deal with the impact of a gravel/sand pack on conductivity estimates, when double straight-line segments exist - which, unintentionally, leads to a larger higher $t_{0.37}$, (e.g. Figure 5), i.e. to a smaller K -value again.

In contrast, when the conductivity of the unconfined aquifer is moderately high to high ($K > 5$ m/d), the K - overestimation error of both methods decreases (Figure 6). The major reason for this is, that because of the fast decay of the slug-induced initial head H_0 in a high conductivity aquifer, a fast subsequent recording of $H(t)$ within a second and less after slug injection is also required. As this can barely be achieved in a real field slug-test, one may, again unintentionally, use a somewhat "later straight-line segment", which partly re-corrects for this overestimation bias for K . For example, Figure 6 shows a simulated case with $S_y = 0.3$, $K = 50$ m/d and a 0.001s - long slug injection. Obviously, the best K - estimate is obtained when using "inadvertently" the "middle straight-line segment", i.e. having missed out on the very early records of the head-drops. In fact, further simulations show that the simulated time $t_{0.37}$ for this case ranges from 1.2s for a 1-m screen length to 0.044s for a 80-m screen length, which for the latter requires indeed a fast and short-sampled recording after slug injection which is seldom possible in a real field slug test.

The above results may be cast in the framework of the hydraulic diffusivity D_H , of an aquifer, defined as $D_H = (K * d) / S_y$ or its scaled inverse, the hydraulic diffusion time $t_D \sim d^2 / D_H = d^2 S_y / K$, where d is a scale length, which could be the radius of the well. D_H determines the transient solution of the parabolic groundwater flow equation (1), such that the diffusion time t_D is the time for a perturbing head pulse to propagate a distance d through the aquifer. Thus, one may say that the slug-test estimation of the hydraulic conductivity K with both the Hvorslev- and the BR- methods work reasonably well, if the "straight-line segments" are somewhat taken in a range that is not much smaller than t_D .

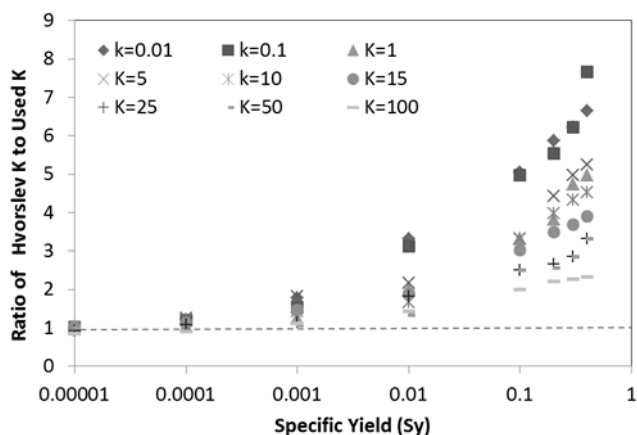

Figure 5. Ratios of estimated conductivity K (m/d) from the Hvorslev method to actual conductivities as a function of the specific yield S_y (unconfined aquifer).

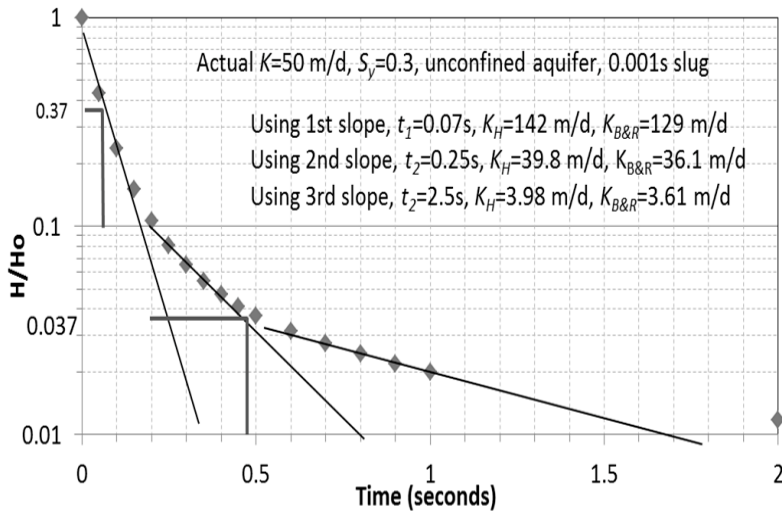

Figure 6. Semi-log plot of H/H_o vs. time of simulated slug tests for an unconfined aquifer with $K=50$ m/d and $S_y=0.3$. t_i is the time for H/H_o to reach 0.37, and K_H and $K_{B\&R}$ are the estimated conductivities from the Hvorslev- and the BR-method, respectively.

6 COMPARISON OF HYDRAULIC CONDUCTIVITIES BETWEEN FIELD PUMPING- AND SLUG TESTS

Extensive field data from 154 slug and 40 pumping tests in an area of roughly 14 square kilometers were obtained from a site at Fort Worth, Texas, during 2002 and 2003. Most of the wells appear to tap into the alluvial deposit, limestone, and some into confining layers. Detailed analyses of the slug tests and the results around the site are reported by Houston and Braun (2004). The average conductivity is 10.17m/d for the slug-test, but 70.01m/d for the pumping tests (Figure 7). One can tell that the conductivities estimated from the slug tests are almost 7 times smaller than the conductivities from the pumping tests (Butler and Healey, 1998).

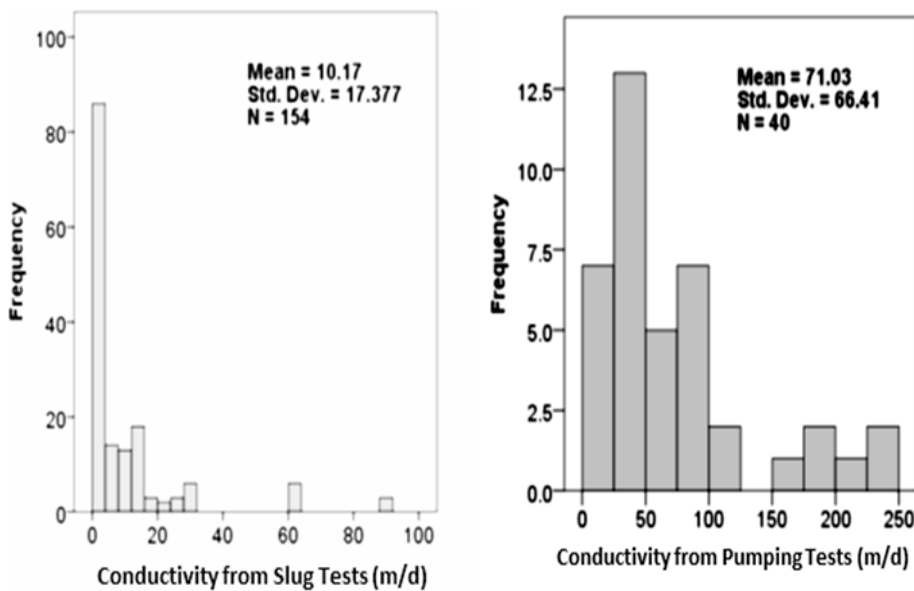

Figure 7. Comparison of conductivity values of slug (left panel) and pumping (right panel) tests from Fort Worth, Texas (Houston and Braun, 2004).

Because conductivities from pumping test are generally considered to better reflect the aquifer's true conductivity, the significant deviation of the conductivity from slug tests from that of pumping tests is begging for explanation. Why, although, theoretically, the slug test is supposed to overestimate the conductivity, particularly, in an unconfined aquifer, is it that, in reality, it's estimated conductivity is almost always smaller than the actual one, if one assumes that the conductivity from the pumping test represents the true conductivity of the aquifer (Butler and Healey, 1998)?

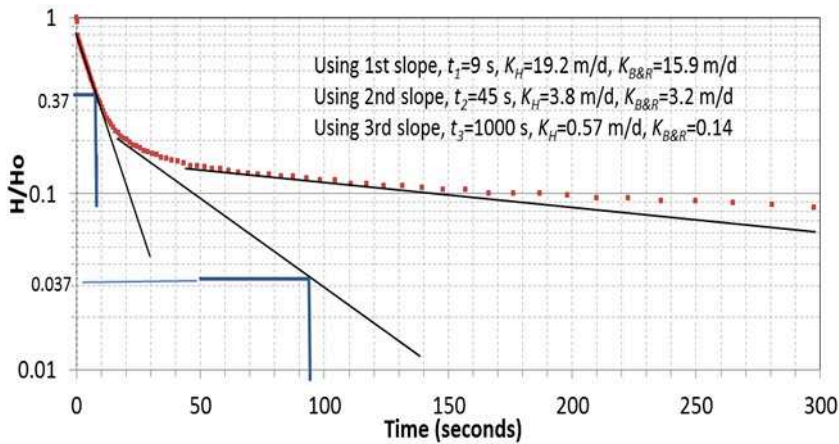

Figure 8. Semi-log plot of $H(t)/H_o$ from well ST14-W23 of Houston and Braun (2004,) with three multi-straight line segments added. The earliest, middle, and last fitted straight line segments are shown. Other symbols in the legend have the same meanings as in Figure 6.

Examining historical studies of pumping test in unconfined aquifers reveals that a significant source of water drag that was ignored in all theoretical slug test equations is the unsaturated flow, as suggested by Boulton (1970). The amount of water drag in a pumping test from unsaturated flow may be insignificant compared with the volume of water flowing to a pumping well. However, it can be quite significant in a slug test situation, due to the small volume of water involved. The smaller the slug size, the larger this effect will be. This drag may be more than sufficient to count the “extra” water gain from the neglect of the storativity in the slug equation. Because the drag of water from unsaturated flow is only significant in an unconfined situation, and slug tests are usually conducted in shallow aquifers, this might, at least partially, explain, why conductivities from slug tests can be significantly smaller than those from pumping tests.

Another possible source of error for the underestimation of the conductivities lies probably in the fitting of the $H(t)/H_o$ - vs time semi-log plot. Figure 8 shows such a plot, together with three multi-straight line-segments, for the slug test at the well tested by Houston and Braun (2004). Thus, similar to the simulated data, depending on which of the three line-segments is used in the analysis, obviously significantly different hydraulic conductivities are obtained. Because high conductivities are generally reported in alluvial aquifers and uniformly high conductivities, in particular, for all the pumping tests from this site, it is likely that a higher conductivity estimate obtained with the early straight-line segment of the head plot reflects the actual conductivity of the aquifer better than the lower conductivity estimate from a later line-segment. Therefore, if the traditional approach of “using the late straight-line segment” for estimating conductivity were used here, it would yield a more erroneous conductivity than that of the early straight-line segment. These results appear to corroborate Butler and Healey (1998), that slug tests made in a high-conductivity aquifer often deliver conductivity estimates too low, as there is a lack of hydraulic data in the first seconds of the test. The third possible source of the underestimation might be the scale effect, as discussed by Butler and Healey (1998) which induces preferential flow paths in a large-scale pumping test. Of course, the inaccurate accounting for the skin effect in a slug test well can also significantly lower the hydraulic conductivities, as it has been surmised in many other previous studies (e.g. Butler, 1998).

Accurate estimation of the hydraulic conductivity from a slug test is made difficult further by many other variations in a slug well, including varied screen lengths, the sand/gravel pack’s high specific yield around the screen, partial penetration, the named well skin effect, and anisotropy of aquifers, as discussed by several researchers (Butler *et al.*, 1994; Rovey II and Niemann, 2001; Malama *et al.*, 2011). In particular, it needs to be cautioned that the first straight-line segment of a slug test can also be associated with the high conductivity of a thick sand/gravel pack around a well screen, or when the latter is only partially submerged under water and the actual aquifer conductivity is low (Binkhorst and Robbins, 1998). In a simplified situation, if a slug test is conducted in a fully penetrating well and isotropic conditions are assumed, and when either the Hvorslev- or the BR method is used for estimating the conductivity and a general conductivity range can be estimated depending on the aquifer type, the recommendation of this study is: for an aquifer with low conductivity (more clayey shale type aquifer with little fractures with $K < 1$ m/d) (large diffusion time), use a “late straight-line segment” (or “0.15 to 0.3 of normalized head”, if the gravel pack effect is limited) to reduce the overestimation; for an aquifer with moderately high to high conductivity (sandstone or crystalline rock with fractures, where K is likely > 5 m/d) (short diffusion time), take the earliest possible hydraulic head reading after slug injection, and use the first straight line-segment; and, lastly, for an aquifer with a conductivity between 1 and 5 m/d, do either a small correction

or no correction, depending on the sampling speed of the hydraulic head recordings after slug injection and the duration of the latter.

REFERENCES

- Binkhorst, G.K., Robbins, G.A., 1998, Conducting and Interpreting Slug Tests in Monitoring Wells with Partially Submerged Screens. *Ground Water*, 36, 225 - 229.
- Bohling, G. C., Butler, J.J. Jr., 2001. Ir2dinv: A finite-difference model for inverse analysis of two-dimensional linear or radial groundwater flow. *Computers & Geosciences*, 27, 1147–1156.
- Boulton, N.S., 1970. Analysis of data from non-equilibrium pumping tests in unconfined anisotropic aquifers. *Journal of Hydrology*, 10, 369-378.
- Bouwer, H., 1989. The Bouwer and Rice slug test--an update. *Ground Water*, 27, 304-309.
- Bouwer, H., Rice, R.C., 1976. A slug test method for determining hydraulic conductivity of unconfined aquifers with completely or partially penetrating wells. *Water Resour. Res.*, 12, 423-428.
- Butler, J.J. Jr., Bohling, G.C., Hyderand, Z., McElwee, C.D., 1994. The use of slug tests to describe vertical variations in hydraulic conductivity. *Journal of Hydrology*, 156, 137-162.
- Butler, J.J. Jr., 1996. Slug tests in site characterization; some practical considerations. *Environmental Geosciences*, 3, 154-163
- Butler, J.J. Jr., Healey, J. M., 1998. Relationship between pumping-test and slug-test parameters: Scale effect or artifact? *Ground Water*, 36, 305-313.
- Butler, J.J., Jr., McElwee, C.D., Liu, W.Z., 1996. Improving the quality of parameter estimates obtained from slug tests. *Ground Water*, 34, 480-490.
- Butler, J.J. Jr., 1998. *The Design, Performance, and Analysis of Slug Tests*. CRC Press, Boca Raton, FL.
- Campbell, M.D., Starrett, M.S., Fowler, J.D., Klein, J.J., 1990. Slug tests and hydraulic conductivity. Proceedings of the "Petroleum Hydrocarbons and Organic Chemicals in Groundwater: Prevention, Detection, and Restoration"-conference, NWWA, Oct-Nov. 1990, Houston, TX, pp. 85-99 (Ground Water Management No.4).
- Chapuis, R. P., 1998. Overdamped slug test in monitoring wells: review of interpretation methods with mathematical, physical, and numerical analysis of storativity influence. *Canadian Geotechnical Journal*, 35, 697-719.
- Chirlin, G. R., 1989. A critique of the Hvorslev method for slug test analysis: the fully penetrating well. *Ground Water Monitoring Review*, 9, 130–138.
- Cooper, H.H., Bredehoeft, J.D., Papadopulos, S.S., 1967. Response of a finite-diameter well to an instantaneous charge of water. *Water Resour. Res.* 3, 263-269.
- Dagan, G., 1978. A note on packer, slug, and recovery tests in unconfined aquifers. *Water Resour. Res.* 14, 929-934.
- Fetter, C.W., 2001, *Applied Hydrogeology*, 4th edition. Prentice Hall, New York, NY.
- Houston, N. A., Braun, C. L., 2004. Analyses and estimates of hydraulic conductivity from slug tests in alluvial aquifer underlying air force plant 4 and Naval Air Station-Joint Reserve Base Carswell Field, Fort Worth, Texas. USGS Scientific Investigations Report 2004–5225, Reston, VA.
- Hvorslev, M.J. 1951. Time Lag and Soil Permeability in Ground-Water Observations. Bulletin 36, Waterways Experimental Station, U.S. Army Corps of Engineering, Vicksburg, MS.
- Hyder, Z., Butler, J.J. Jr., McElwee, C.D., Liu, W., 1994. Slug tests in partially penetrating wells. *Water Resour. Res.*, 30, 2945-2957.
- Hyder, Z., Butler, J. J. Jr., 1995. Slug tests in unconfined formations: an assessment of the Bouwer and Rice technique. *Ground Water*. 33, 16–22.
- Leap, D.I. 1984. A simple pneumatic device and technique for performing rising water level slug tests. *Ground Water Monitoring Review*, 4, 141-146.
- Malama B., Kuhlman, Barrash, K. L., Cardiff, W., M., Thoma M., 2011. Modeling slug tests in unconfined aquifers taking into account water table kinematics, wellbore skin and inertial effects. *Journal of Hydrology*, 408, 113-126.
- McDonald, M.G., Harbaugh, A.W., 1983. A modular three-dimensional finite-difference ground-water flow model. U.S. Geological Survey Open-File Report 83-875, Reston, VA..
- McElwee, C.D., Bohling, G.C., Butler, J.J. Jr., 1995 a. Sensitivity analysis of slug tests I: The slugged well. *Journal of Hydrology*, 164, 53-67.
- McElwee, C.D., Butler, J.J. Jr., Bohling, G.C., 1995 b. Sensitivity analysis of slug tests II: Observation wells. *Journal of Hydrology*, 164, 69-87.
- Morris, D.A., Johnson, A.I., 1967. Summary of hydrologic and physical properties of rock and soil materials as analyzed by the Hydrologic Laboratory of the U.S. Geological Survey 1948-1960. U.S. Geolog. Surv. Wat. Sup. Pap. 1839-D. 42 pp.
- Neuman, S.P., Witherspoon, P.A., 1969. Applicability of current theories of flow in leaky aquifers. *Water Resour. Res.*, 5, 817-829.
- Neuman, S.P. 1975. Analysis of pumping test data from anisotropic unconfined aquifers considering delayed gravity response. *Water Resour. Res.*, 11, 329-342.
- Rovey C. W., Niemann, W. L., 2001. Wellskins and slug tests: Where's the bias? *Journal of Hydrology*, 243, 120–132.
- Todd, D. K., Mays, L.W. 2005. *Groundwater Hydrology*. John Wiley and Sons, New York, NY.
- Zurbuchen, B.R., Zlotnik, V.A., Butsler, J.J. Jr., 2002. Dynamic interpretation of slug tests in highly permeable aquifers. *Water Resour. Res.*, 38, 1025, doi:10.1016/j.jhydro.2007.08.018, 18pp.