

# HENRY

Hydraulic Engineering Repository

Ein Service der Bundesanstalt für Wasserbau

---

Conference Paper, Published Version

**Richardson, Everett V.; Jones, Sterling J.; Sheppard, Max D.**  
**New Approach to Scour Evaluation of Complex Bridge Piers**

---

Verfügbar unter/Available at: <https://hdl.handle.net/20.500.11970/100384>

Vorgeschlagene Zitierweise/Suggested citation:

Richardson, Everett V.; Jones, Sterling J.; Sheppard, Max D. (2002): New Approach to Scour Evaluation of Complex Bridge Piers. In: Chen, Hamn-Ching; Briaud, Jean-Louis (Hg.): First International Conference on Scour of Foundations. November 17-20, 2002, College Station, USA. College Station, Texas: Texas Transportation Inst., Publications Dept.. S. 810-826.

**Standardnutzungsbedingungen/Terms of Use:**

Die Dokumente in HENRY stehen unter der Creative Commons Lizenz CC BY 4.0, sofern keine abweichenden Nutzungsbedingungen getroffen wurden. Damit ist sowohl die kommerzielle Nutzung als auch das Teilen, die Weiterbearbeitung und Speicherung erlaubt. Das Verwenden und das Bearbeiten stehen unter der Bedingung der Namensnennung. Im Einzelfall kann eine restriktivere Lizenz gelten; dann gelten abweichend von den obigen Nutzungsbedingungen die in der dort genannten Lizenz gewährten Nutzungsrechte.

Documents in HENRY are made available under the Creative Commons License CC BY 4.0, if no other license is applicable. Under CC BY 4.0 commercial use and sharing, remixing, transforming, and building upon the material of the work is permitted. In some cases a different, more restrictive license may apply; if applicable the terms of the restrictive license will be binding.



## **New Approach to Scour Evaluation of Complex Bridge Piers**

**by  
Everett V. Richardson,<sup>1</sup> J. Sterling Jones,<sup>2</sup> and D. Max Sheppard<sup>3</sup>**

### **ABSTRACT**

Complex bridge piers are those that have two or three substructural elements subjected to the flow. These substructural elements are the pier stem, pile cap or footing, and piles. Two or more of the substructural elements may be subjected to the flow by design or by long term degradation and/or contraction scour. Ongoing research has determined that the total scour depth can best be determined by separating the complex pier into each of its substructural elements, determine the scour depth for each element and adding them. This paper presents equations and procedures to determine scour depths for the design of new bridges and evaluation of existing bridges with complex pier foundations. However, physical model studies are recommended for complex piers to reduce uncertainty, increase the safety of the design, and reduce cost.

### **INTRODUCTION**

The U.S. Department of Transportation, Federal Highway Administration (FHWA) in 1988 issued a Technical Advisory requiring the States to evaluate the scour vulnerability of all highway bridges over water. A publication titled "Interim Procedures for Evaluating Scour at Bridges" was issued as an attachment. In 1991 the attachment was modified and issued as Hydraulic Engineering Circular 18 (HEC 18) titled "Evaluation Scour at Bridges". In 1993 an updated second edition was issued. Followed in 1995 by a third edition and in 2001 by a fourth edition (Richardson et al, 2001). In addition, in 1991 HEC 20 titled "Stream Stability at Highway Structures" was issued. Followed by the second edition in 1995, and a third edition in 2001 (Lagasse et al, 2001). In 1997 HEC 23 titled "Bridge Scour and Stream Instability Countermeasures" was issued with a second edition in 2001 (Lagasse et al, 2001).

These three publications (HEC 18, 20 and 23) comprise a set of three publications for the use by the States in the design and evaluation of their bridges for scour and stream instability. In the Fourth Edition of HEC 18 a new and improved approach was added for the scour evaluation of complex piers. A complex pier is one where two or more of the foundation components (piles, pile cap or footing and pier shaft) are or may be exposed to the flow. This paper will describe and illustrate this new approach which was developed at the Turner-Fairbank and Florida University research laboratories. In using these methods engineering judgment must be used. Engineering judgment should take into consideration the volume of traffic, type of traffic (school bus, ambulance, fire trucks, local road, interstate, etc.), the importance of the highway, cost of a failure (potential loss of life and dollars) and the increase in cost that would occur if the most conservative scour depth is used.

---

<sup>1</sup> Senior Associate, Ayres Associates, P. O. Box 270460 and Professor Emeritus of Civil Engineering, Colorado State University, Fort Collins, Co

<sup>2</sup> Research Hydraulic Engineer, Federal Highway Administration, Turner-Fairbank Highway Research Center, 6300 Georgetown Pile, McLean, VA

<sup>3</sup> Professor of Coastal and Oceanographic Engineering, University of Florida, Gainesville, FL

## TOTAL SCOUR

Total scour at a highway bridge is composed of the following elements

- Long term degradation of the stream bed
- General scour (contraction scour is the main component)
- Local scour at the piers and abutments
- Stream instability

## LOCAL SCOUR AT BRIDGE PIERS

Using a study by Jones (1983) of the many equations for the determination of local scour at piers an equation based on the CSU equation (Richardson et al, 1975) was recommended for both live-bed and clear-water pier scour in the Interim Procedures for Evaluating Scour at Bridges. With modifications the CSU equation is the base equation for editions of HEC 18. Mueller (1996), using 384 field scour measurements at 56 bridges to compare 22 equations, concluded that the HEC 18 equation was good for design. The equation predicts maximum pier scour depths. The HEC 18 equation is:

$$\frac{y_s}{y_1} = 2.0 K_1 K_2 K_3 K_4 K_w \left( \frac{a}{y_1} \right)^{0.65} Fr_1^{0.43} \quad (1)$$

where:

- $y_s$  = Scour depth, m (ft)
- $y_1$  = Flow depth directly upstream of the pier, m (ft)
- $K_1$  = Correction factor for pier nose shape from table 1
- $K_2$  = Correction factor for angle of attack of flow from equation 3
- $K_3$  = Correction factor for bed condition from table 3
- $K_4$  = Correction factor for armoring by bed material size, see HEC 18
- $K_w$  = Correction factor for wide piers, equations 4 and 5
- $a$  = Pier width, m (ft)
- $L$  = Length of pier, m (ft)
- $Fr_1$  = Froude Number directly upstream of the pier =  $V_1/(gy_1)^{1/2}$
- $V_1$  = Mean velocity of flow directly upstream of the pier, m/s (ft/s)
- $g$  = Acceleration of gravity (9.81 m/s<sup>2</sup>) (32.2 ft/s<sup>2</sup>)

$$K_2 = (\cos \theta + L/a \sin \theta)^{0.65} \quad (2)$$

If  $L/a$  is larger than 12, use  $L/a = 12$  as a maximum in Equation 2.

Table 2 illustrates the magnitude of the effect of the angle of attack on local pier scour.

Shape of Pier Nose	$K_1$
(a) Square nose	1.1
(b) Round nose	1.0
(c) Circular cylinder	1.0
(d) Group of cylinders	1.0
(e) Sharp nose	0.9

Angle	L/a=4	L/a=8	L/a=12
0	1.0	1.0	1.0
15	1.5	2.0	2.5
30	2.0	2.75	3.5
45	2.3	3.3	4.3
90	2.5	3.9	5.0

Angle = skew angle of flow  
L = length of pier, a = pier width

Bed Condition	Dune Height ft	$K_3$
Clear-Water Scour	N/A	1.1
Plane bed and Antidune flow	N/A	1.1
Small Dunes	$3 > H > 0.6$	1.1
Medium Dunes	$9 > H > 3$	1.2 to 1.1
Large Dunes	$H > 9$	1.3

**Notes:**

1. The values of the correction factor  $K_2$  should be determined using the length of the pier actually subjected to the angle of attack of the flow. Also, Piers set close to abutments must be carefully evaluated for the angle of attack and velocity of the flow coming around the abutment.
2. The correction factor  $K_3$  results from the fact that in sand bed streams a plane-bed or antidunes will exist at most bridge sites for the flood frequencies employed in scour design. When large dunes exist during flood flow, the maximum pier scour may be 30 percent greater than the predicted equation value. This may occur on very large rivers, such as the Mississippi. For smaller streams with a dune bed configuration at flood flow, the dunes will be smaller and the maximum scour may be only 10 to 20 percent larger.
3. The correction factor  $K_4$  decreases scour depths for armoring of the scour hole for coarse bed materials (Mueller & Jones, 1999). Equations to compute  $K_4$  are given in the third and fourth editions of HEC 18. However, research is continuing to improve methods to determine  $K_4$ .
4. The correction factor,  $K_w$  (Johnson and Torrico, 1994) is applied when the ratio of depth of flow ( $y$ ) to pier width ( $a$ ) is less than 0.8 ( $y/a < 0.8$ ); the ratio of pier width ( $a$ ) to the median diameter of the bed material ( $D_{50}$ ) is greater than 50 ( $a/D_{50} > 50$ ); and the Froude Number of the flow is subcritical. Engineering judgment is needed in applying  $K_w$  because it is based on limited flume data.

The equations for  $K_w$  are:

$$K_w = 2.58 \left( \frac{y}{a} \right)^{0.34} Fr_1^{0.65} \quad \text{for } V / V_c < 1 \quad (3)$$

$$K_w = 1.0 \left( \frac{y}{a} \right)^{0.13} Fr_1^{0.25} \quad \text{for } V / V_c \geq 1 \quad (4)$$

where:

$V_c$  = Critical velocity of the  $D_{50}$  bed material size (see HEC 18).  
The other variables as previously defined.

## SCOUR FOR COMPLEX PIER FOUNDATIONS

### Introduction

Most pier scour research has focused on solid piers with limited attention to determining scour depths when (1) pile groups, (2) pile groups and pile caps, or (3) pile groups, pile caps and solid piers are exposed to the flow (Salim and Jones, 1995, 1996, and 1999). The three types of exposure to the flow may be by design or long-term degradation, general (contraction) scour, and local scour, in addition to stream migration. In the general case, the flow could be obstructed by three substructural elements (the pier stem, the pile cap or footing, and the pile group). Ongoing research (Jones and Sheppard, 2000, Sheppard, 2001) has determined methods and equations to determine scour depths for complex pier foundations. The results of this research are given in HEC 18 and the following sections. The following steps are recommended for determining the depth of scour for any combination of the three substructural elements exposed to the flow.

- The scour depths should be determined for the 100-year flood or smaller discharge if it causes deeper scour and a superflood. A 500-year flood, is recommended in HEC 18.
- If needed, use computer programs to compute the hydraulic variables.
- Analyze the complex pile configuration to determine the components of the pier that are exposed or will be exposed to the flow.
- Determine the scour depths for each component exposed to the flow using the equations and methods presented in the following sections.
- Add the components to determine the total scour depths.
- Plot the scour depths and analyze the results using an interdisciplinary team to determine their reliability and adequacy for the bridge, flow and site conditions, safety and costs.
- Conduct a physical model study if engineering judgment determines it will reduce uncertainty, increase the safety of the design, and/or reduce cost.

## Superposition of Scour Components Method of Analysis

The components of a complex pier are illustrated in Figure 1. Note that the pile cap can be above the water surface, at the water surface, in the water or on the bed. The location of the pile cap may result from design or from long-term degradation and/or contraction scour. The pile group, as illustrated, is in uniform (lined up) rows and columns. This may not always be the case. The support for the bridge in many flow fields and designs may require a more complex arrangement of the pile group. In more complex pile group arrangements, the methods of analysis given in this manual may give smaller or larger scour depths.

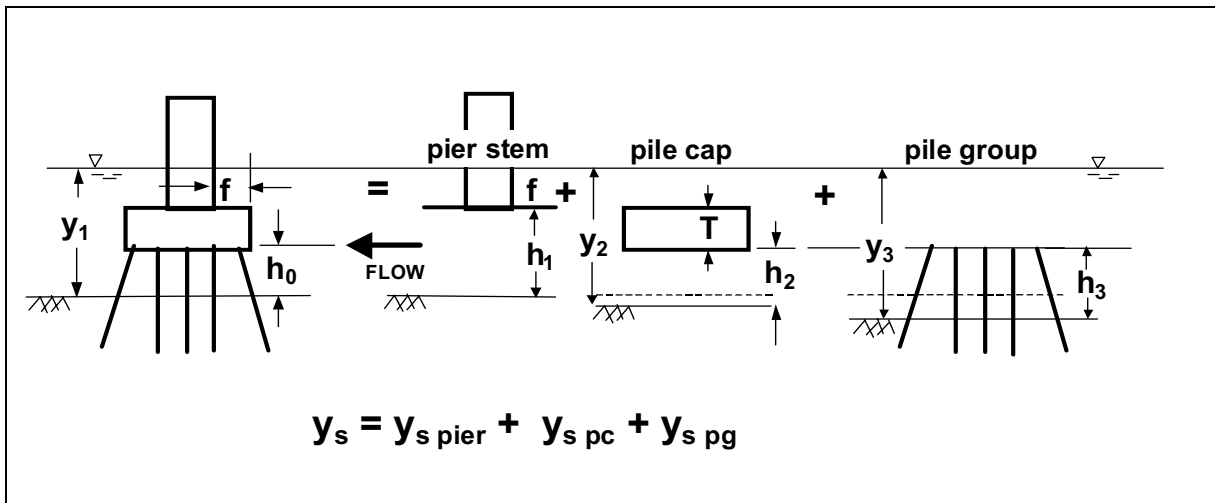

Figure 1. Scour components for a complex pier (Jones and Sheppard (2000)).

The variables illustrated in Figure 1 and others used in computations are as follows:

- $f$  = Distance between front edge of pile cap or footing and pier, m (ft)
- $h_o$  = Height of the pile cap above bed at beginning of computation, m (ft)
- $h_1$  =  $h_o + T$  = height of the pier stem above the bed before scour, m (ft)
- $h_2$  =  $h_o + y_{s \text{ pier}}/2$  = height of pile cap after pier stem scour component has been computed, m (ft)
- $h_3$  =  $h_o + y_{s \text{ pier}}/2 + y_{s \text{ pc}}/2$  = height of pile group after the pier stem and pile cap scour components have been computed, m (ft)
- $S$  = Spacing between columns of piles, pile center to pile center, m (ft)
- $T$  = Thickness of pile cap or footing, m (ft)
- $y_1$  = Approach flow depth at the beginning of computations, m (ft)
- $y_2$  =  $y_1 + y_{s \text{ pier}}/2$  = adjusted flow depth for pile cap computations, m (ft)
- $y_3$  =  $y_1 + y_{s \text{ pier}}/2 + y_{s \text{ pc}}/2$  = adjusted flow depth for pile group computations, m (ft)
- $V_1$  = Approach velocity used at the beginning of computations, m/sec (ft/sec)
- $V_2$  =  $V_1(y_1/y_2)$  = adjusted velocity for pile cap computations, m/sec (ft/sec)
- $V_3$  =  $V_1(y_1/y_3)$  = adjusted velocity for pile group computations, m/sec (ft/sec)

Total scour from superposition of components is given by:

$$y_s = y_{s \text{ pier}} + y_{s \text{ pc}} + y_{s \text{ pg}} \quad (5)$$

where:

- $y_s$  = Total scour depth, m (ft)
- $y_{s \text{ pier}}$  = Scour component for the pier stem in the flow, m (ft)
- $y_{s \text{ pc}}$  = Scour component for the pier cap or footing in the flow, m (ft)
- $y_{s \text{ pg}}$  = Scour component for the piles exposed to the flow, m (ft)

Each of the scour components is computed from the basic pier scour Equation 1 using an equivalent sized pier to represent the irregular pier components, adjusted flow depths and velocities as described in the list of variables for Figure 2, and height adjustments for the pier stem and pile group. The height adjustment is included in the equivalent pier size for the pile cap.

### Determination of the Pier Stem Scour Depth Component

The need to compute the pier stem scour depth component occurs when the pier cap or the footing is in the flow and the pier stem is subjected to sufficient flow depth and velocity as to cause scour. The first computation is the scour estimate,  $y_{s \text{ pier}}$ , for a full depth pier that has the width and length of the pier stem using Equation 1. In Equation 1,  $a_{\text{pier}}$  is the pier width and other variables in the equation are as defined previously. This base scour estimate is multiplied by  $K_{h \text{ pier}}$ , given in Figure 2 as a function of  $h_1/a_{\text{pier}}$  and  $f/a_{\text{pier}}$ , to yield the pier stem scour component as follows:

$$\frac{y_{s \text{ pier}}}{y_1} = K_{h \text{ pier}} \left[ 2.0 K_1 K_2 K_3 K_4 K_w \left( \frac{a_{\text{pier}}}{y_1} \right)^{0.65} \left( \frac{V_1}{\sqrt{g y_1}} \right)^{0.43} \right] \quad (6)$$

where:

- $K_{h \text{ pier}}$  = Coefficient to account for the height of the pier stem above the bed and the shielding effect by the pile cap overhang distance "f" in front of the pier stem (from Figure 2)

The quantity in the square brackets in Equation 6 is the basic pier scour ratio as if the pier stem were full depth and extended below the scour.

### Determination of the Pile Cap (Footing) Scour Depth Component

The pile cap or footing scour depth component is calculated when the pile cap is in the flow by design, or as the result of long-term degradation, contraction scour, and/or by local scour attributed to the pier stem above it. As described below, there are two cases to consider in estimating the scour caused by the pile cap (or footing). Equation 1 is used to estimate the scour component in both cases, but the conceptual strategy for determining the variables to be used in the equation is different (partly due to limitations in the research that has been done to date

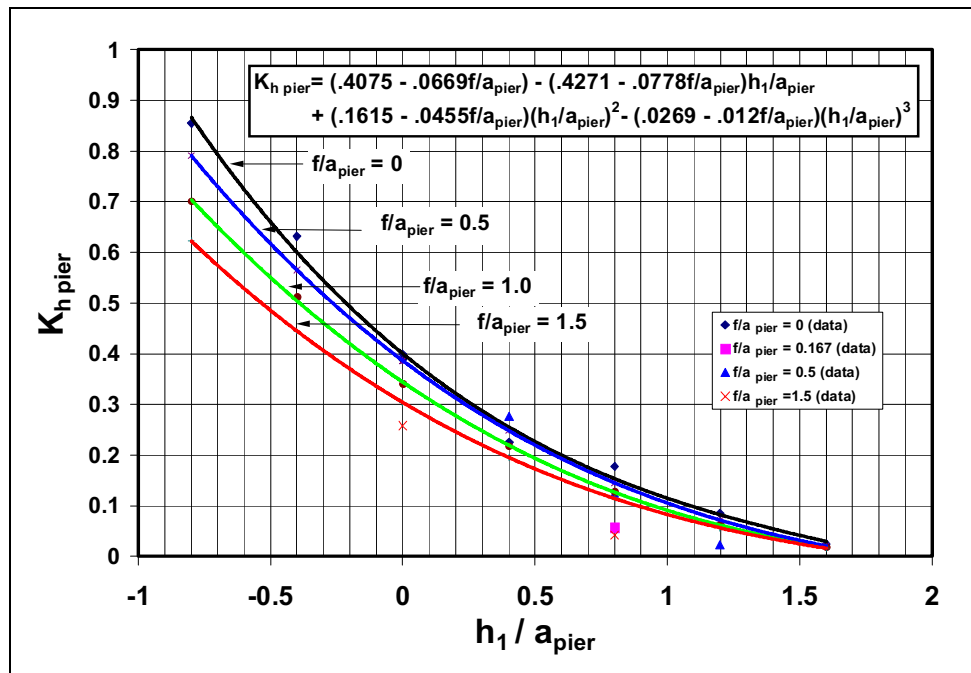

Figure 2. Suspended pier scour ratio (Jones and Sheppard (2000)).

Case 1: The bottom of the pile cap is above the bed and in the flow either by design or after the bed has been lowered by scour caused by the pier stem component. The strategy is to reduce the pile cap width,  $a_{pc}$ , to an equivalent full depth solid pier width,  $a_{pc}^*$ , using Figure 3. The equivalent pier width, an adjusted flow depth,  $y_2$ , and an adjusted flow velocity,  $V_2$ , are then used in Equation 1 to estimate the scour component.

Case 2: The bottom of the pile cap or footing is on or below the bed. The strategy is to treat the pile cap or exposed footing like a short pier in a shallow stream of depth equal to the height to the top of the footing above bed. The portion of the flow that goes over the top of the pile cap or footing is ignored. Then, the full pile cap width,  $a_{pc}$ , is used in the computations, but the exposed footing height,  $y_f$ , (in lieu of the flow depth), and the average velocity,  $V_f$ , in the portion of the profile approaching the footing are used in Equation 1 to estimate the scour component.

An inherent assumption in this second case is that the footing is deeper than the scour depth so it is not necessary to add the pile group scour as a third component in this case. If the bottom of the pile cap happens to be right on the bed, either the case 1 or case 2 method could be applied, but they won't necessarily give the same answers. If both methods are tried, then engineering judgment should dictate which one to accept.

Details for determining the pile cap or footing scour component for these two cases are described in the following paragraphs.



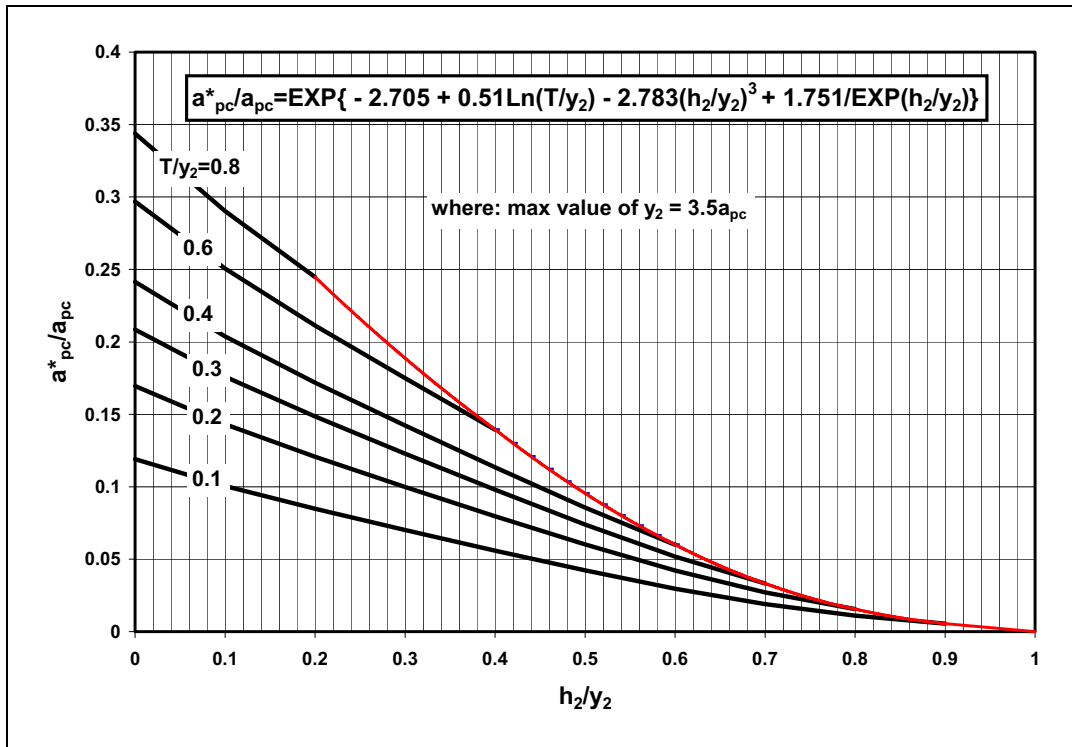

Figure 3. Pile cap (footing) equivalent width (Jones and Sheppard (2000)).

### Case 1. Bottom of the Pile Cap (Footing) in the Flow above the Bed

- $T$  = Thickness of the pile cap exposed to the flow, m (ft)  
 $h_2$  =  $h_o + y_{s \text{ pier}}/2$ , m (ft)  
 $y_2$  =  $y_1 + y_{s \text{ pier}}/2$ , = adjusted flow depth, m (ft)  
 $V_2$  =  $V_1(y_1/y_2)$  = adjusted flow velocity, m/s (ft/s)

where:

- $h_o$  = Original height of the pile cap above the bed, m (ft)  
 $y_1$  = Original flow depth at the beginning of the computations before scour, m (ft)  
 $y_{s \text{ pier}}$  = Pier stem scour depth component, m (ft)  
 $V_1$  = Original approach velocity at the beginning of the computations, m/s (ft/s)

Determine  $a^*_{pc}/a_{pc}$  from Figure 3 as a function of  $h_2/y_2$  and  $T/y_2$  (note that the maximum value of  $y_2 = 3.5 a_{pc}$ ).

Compute  $a^*_{pc} = (a^*_{pc}/a_{pc}) a_{pc}$ ; where  $a^*_{pc}$  is the width of the equivalent pier to be used in Equation 1 and  $a_{pc}$  is the width of the original pile cap. Compute the pile cap scour component,  $y_{s \text{ pc}}$  from Equation 1 using  $a^*_{pc}$ ,  $y_2$ , and  $V_2$  as the pier width, flow depth, and velocity parameters, respectively. The rationale for using the adjusted velocity for this computation is that the near bottom velocities are the primary currents that

produce scour and they tend to be reduced in the local scour hole from the overlying component. **For skewed flow use the L/a for the original pile cap as the L/a for the equivalent pier to determine  $K_2$ .** Apply the wide pier correction factor,  $K_w$ , if (1) the total depth,  $y_2 < 0.8 a^*_{pc}$ , (2) the Froude Number  $V_2/(g y_2)^{1/2} < 1$ , and (3)  $a^*_{pc} > 50 D_{50}$ . The scour component equation for the case 1 pile cap can then be written:

$$\frac{y_{s pc}}{y_2} = 2.0 K_1 K_2 K_3 K_4 K_w \left( \frac{a^*_{pc}}{y_2} \right)^{0.65} \left( \frac{V_2}{\sqrt{g y_2}} \right)^{0.43} \quad (7)$$

Next, the pile group scour component should be computed.

### Case 2. Bottom of the Pile Cap (Footing) Located On or Below the Bed.

One limitation of the procedure described above is that the design chart in Figure 3 has not been developed for the case of the bottom of the pile cap or footing being below the bed (i.e., negative values of  $h_2$ ). In this case, use a modification of the exposed footing procedure that has been described in previous editions of HEC-18. The previous procedure was developed from experiments in which the footing was never undermined by scour and tended to be an over predictor if the footing is undermined.

As for case 1:

$$\begin{aligned} y_2 &= y_1 + y_{s \text{ pier}}/2, \text{ m (ft)} \\ V_2 &= V_1(y_1/y_2), \text{ m/s (ft/s)} \end{aligned}$$

The average velocity of flow at the exposed footing ( $V_f$ ) is determined using the following equation:

$$\frac{V_f}{V_2} = \frac{\ln\left(10.93 \frac{y_f}{k_s} + 1\right)}{\ln\left(10.93 \frac{y_2}{k_s} + 1\right)} \quad (8)$$

where:

- $V_f$  = Average velocity in the flow zone below the top of the footing, m/s (ft/s)
- $V_2$  = Average adjusted velocity in the vertical of flow approaching the pier, m/s (ft/s)
- In = Natural log to the base e
- $y_f$  =  $h_1 + y_{s \text{ pier}}/2$  = distance from the bed (after degradation, contraction scour, and pier stem scour) to the top of the footing, m (ft)
- $k_s$  = Grain roughness of the bed (normally taken as the  $D_{84}$  for sand size bed material and  $3.5 D_{84}$  for gravel and coarser bed material), m (ft)
- $y_2$  = Adjusted depth of flow upstream of the pier, including degradation, contraction scour and half the pier stem scour, m (ft)

See Figure 4 for an illustration of variables.

Compute the pile cap scour depth component,  $y_{s\ pc}$  from Equation 1 using the full pile cap width,  $a_{pc}$ ,  $y_f$ ,  $V_f$  as the width, flow depth, and velocity parameters, respectively. The wide pier factor  $K_w$  should be used in this computation if (1) the total depth  $y_2 < 0.8 a_{pc}$ , (2) the Froude Number  $V_2/(gy_2)^{1/2} < 1$ , and (3)  $a_{pc} > 50 D_{50}$ . Use  $y_2/a_{pc}$  to compute the  $K_w$  factor if it is applicable. The scour component equation for the case 2 pile cap or footing can then be written:

$$\frac{y_{s\ pc}}{y_f} = 2.0K_1K_2K_3K_4K_w \left( \frac{a_{pc}}{y_f} \right)^{0.65} \left( \frac{V_f}{\sqrt{gy_f}} \right)^{0.43} \quad (9)$$

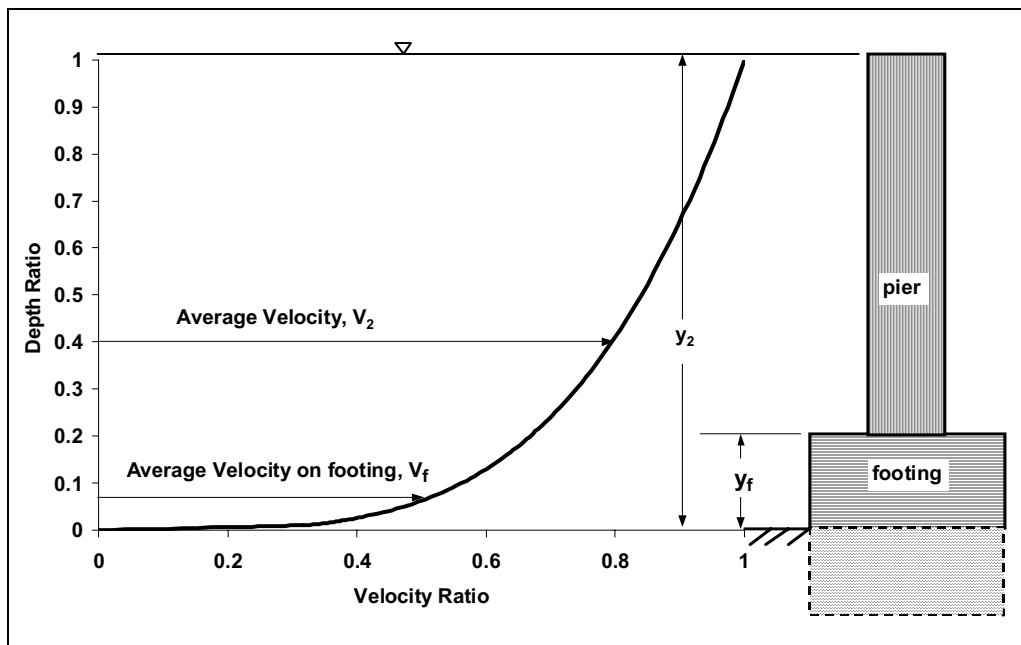

Figure 4. Definition sketch for velocity and depth on exposed footing.

In this case assume the pile cap scour component includes the pile group scour and compute the total scour depth as:

$$y_s = y_{s\ pier} + y_{s\ pc} \quad (\text{For case 2 only}) \quad (10)$$

### Determination of the Pile Group Scour Depth Component

Research by Salim and Jones (1995, 1996, and 1999) and Jones 1989 and by Smith (1999) has provided a basis for determining pile group scour depth by taking into consideration the spacing between piles, piles aligned or staggered, angle of attack, the number of pile rows and a height factor to account for the pile length exposed to the flow. Procedures are given for analyzing the following typical cases:

- Special case of piles aligned with each other and with the flow. No angle of attack.
- General case of the pile group skewed to the flow, with an angle of attack, or pile groups with staggered rows of piles.

The strategy for estimating the pile group scour component is the same for both cases, but the technique for determining the projected width of piles is simpler for the special case of aligned piles. The strategy is as follows:

- Project the width of the piles onto a plane normal to the flow.
- Determine the effective width of an equivalent pier that would produce the same scour if the pile group penetrated the water surface.
- Adjust the flow depth, velocity and exposed height of the pile group to account for the pier stem and pile cap scour components previously calculated.
- Determine the pile group height factor based on the exposed height of the pile group above the bed.
- Compute the pile group scour component using a modified version of Equation 1.

For the special case of aligned piles, the projected width,  $a_{proj}$ , onto a plane normal to the flow is simply the width of the collapsed pile group as illustrated in Figure 5.

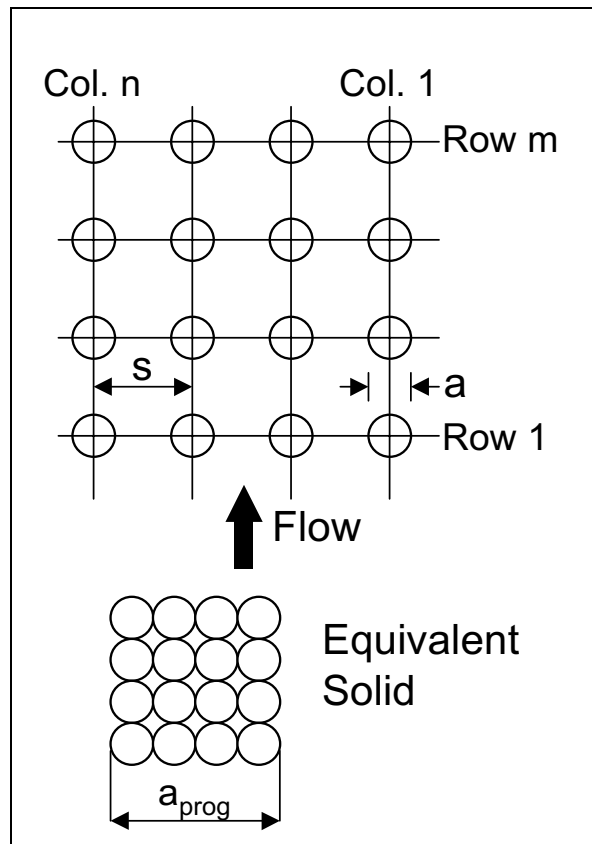

Figure 5. Projected width of piles for the special case of aligned flow.

For the general case, Smith (1999) determined that a pile group could be represented by an equivalent solid pier that has an effective width,  $a^*_{pg}$ , equal to a spacing factor multiplied by the sum of the non-overlapping projected widths of the piles onto a plane normal to the flow direction (Figure 6). The procedure for the general case is the same as the procedure for the aligned pile groups except for the determination of the width of the equivalent solid which is a more tedious process for the general case. The sum of the projected widths can be determined by sketching the pile group to scale and projecting the outside edges of each pile onto the projection plane as illustrated in Figure 6 or by systematically calculating coordinates of the edges of each pile along the projection plane. The coordinates are sorted in ascending order to facilitate inspection to eliminate double counting of overlapping areas. Additional experiments are being conducted at the FHWA hydraulics laboratory to test simpler techniques for estimating the effective width, but currently Smith's summation technique is a logical choice.

Smith attempted to derive weighting factors to adjust the impact of piles according to their distance from the projection plane, but concluded that there was not enough data and the procedure would become very cumbersome with weighting factors. A reasonable alternative to using weighting factors is to exclude piles other than the two rows and one column closest to the plane of projection as illustrated by the bold outlines in Figure 6.

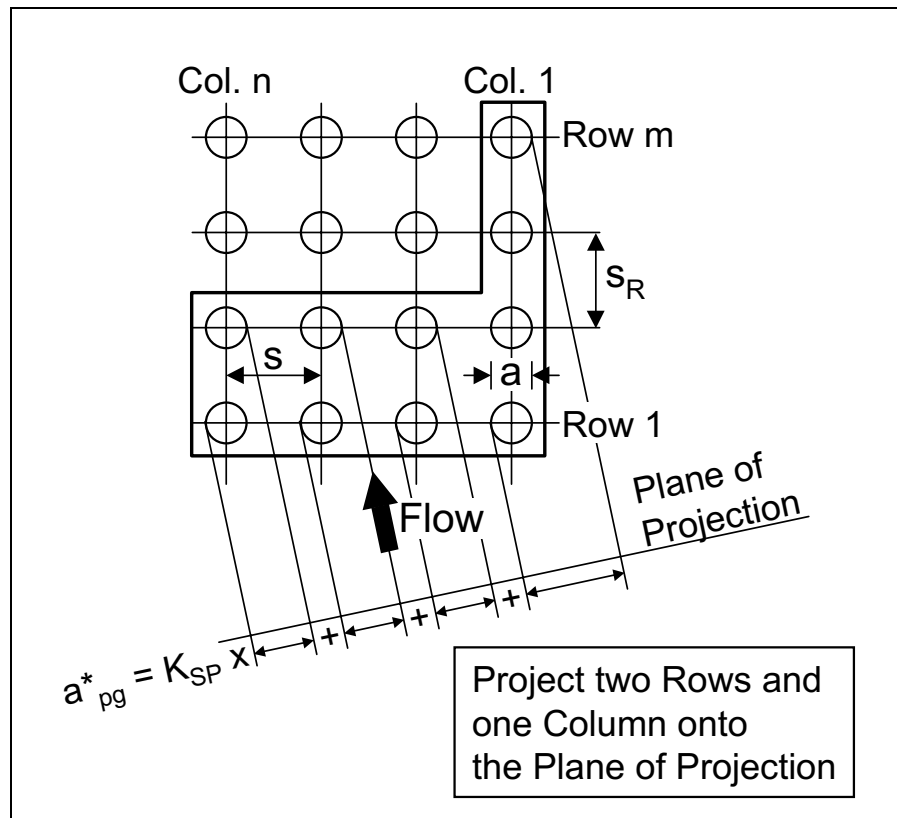

Figure 6. Projected width of piles for the general case of skewed flow.

### Effective width of an equivalent full depth pier

The effective width of an equivalent full depth pier is the product of the projected width of piles multiplied by a spacing factor and a number of aligned rows factor (used for the special case of aligned piles only).

$$a_{pg}^* = a_{proj} K_{sp} K_m \quad (11)$$

where:

- $a_{proj}$  = Sum of non-overlapping projected widths of piles (see Figures 5 and 6)
- $K_{sp}$  = Coefficient for pile spacing (Figure 7)
- $K_m$  = Coefficient for number of aligned rows,  $m$ , (Figure 8).  $K_m$  is constant for all  $S/a$  values when there are more than 6 rows of piles.
- $K_m$  = 1.0 for skewed or staggered pile groups

The number of rows factor,  $K_m$ , is 1.0 for the general case of skewed or staggered rows of piles because the projection technique for skewed flow accounts for the number of rows and is already conservative for staggered rows.

The adjusted flow depth and velocity to be used in the pier scour equation are as follows:

$$y_3 = y_1 + y_{s \text{ pier}}/2 + y_{s \text{ pc}}/2, \text{ m (ft)} \quad (12)$$

$$V_3 = V_1 (y_1/y_3), \text{ m/s (ft/s)} \quad (13)$$

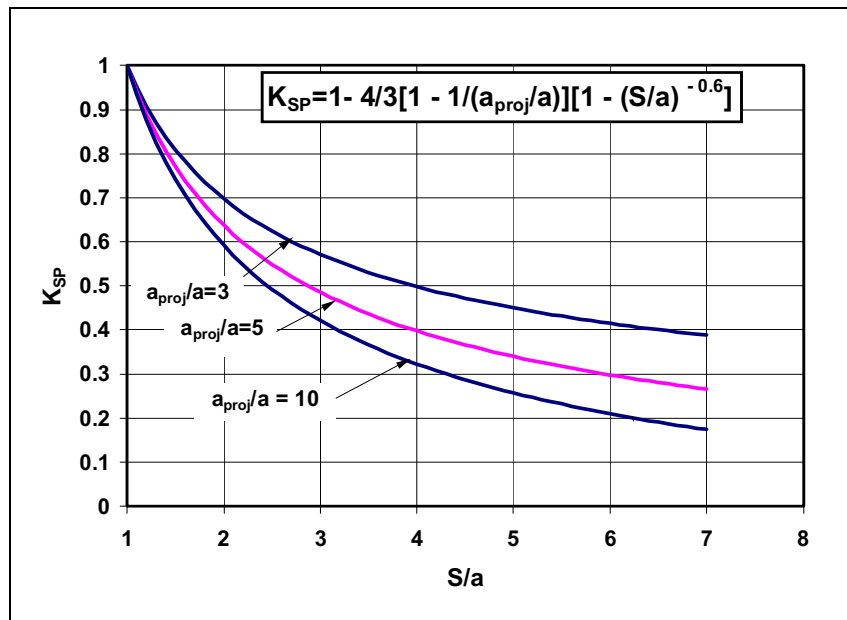

Figure 7 Pile spacing factor ( Sheppard, 2001)

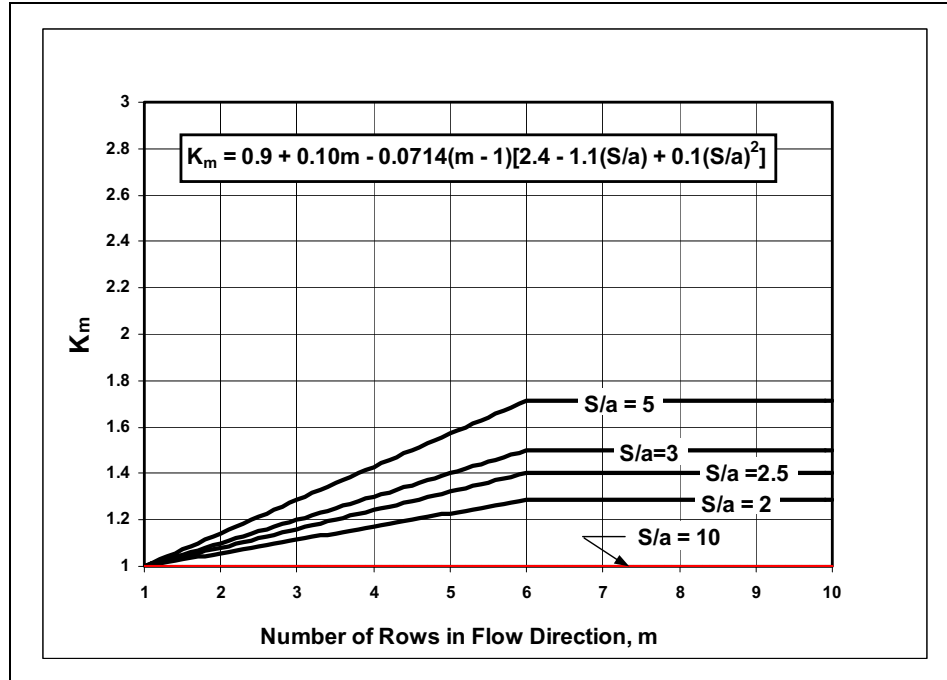

Figure 8. Adjustment factor for number of aligned rows of piles (Sheppard, 2001).

The scour equation for a pile group can then be written as follows:

$$\frac{y_{s\text{pg}}}{y_3} = K_{\text{hpg}} \left[ 2.0K_1K_3K_4 \left( \frac{a^*_{\text{pg}}}{y_3} \right)^{0.65} \left( \frac{V_3}{\sqrt{gy_3}} \right)^{0.43} \right] \quad (14)$$

where:

- $K_h$  = Pile group height factor given in Figure 9 as function of  $h_3/y_3$  (note that the maximum value of  $y_3 = 3.5 a^*_{\text{pg}}$ )
- $K_{\text{pg}}$  =
- $h_3$  =  $h_0 + y_{s\text{ pier}}/2 + y_{s\text{ pc}}/2$  = height of pile group above the lowered stream bed after pier and pile cap scour components have been computed, m, (ft)

$K_2$  from Equation 1 has been omitted because pile widths are projected onto a plane that is normal to the flow. The quantity in the square brackets is the scour ratio for a solid pier of width,  $a^*_{\text{pg}}$ , if it extended to the water surface. This is the scour ratio for a full depth pile group.

### Determination of Total Scour Depth for the Complex Pier

The total scour for the complex pier from Equation (5) is:

$$y_s = y_{s\text{ pier}} + y_{s\text{ pc}} + y_{s\text{ pg}}$$

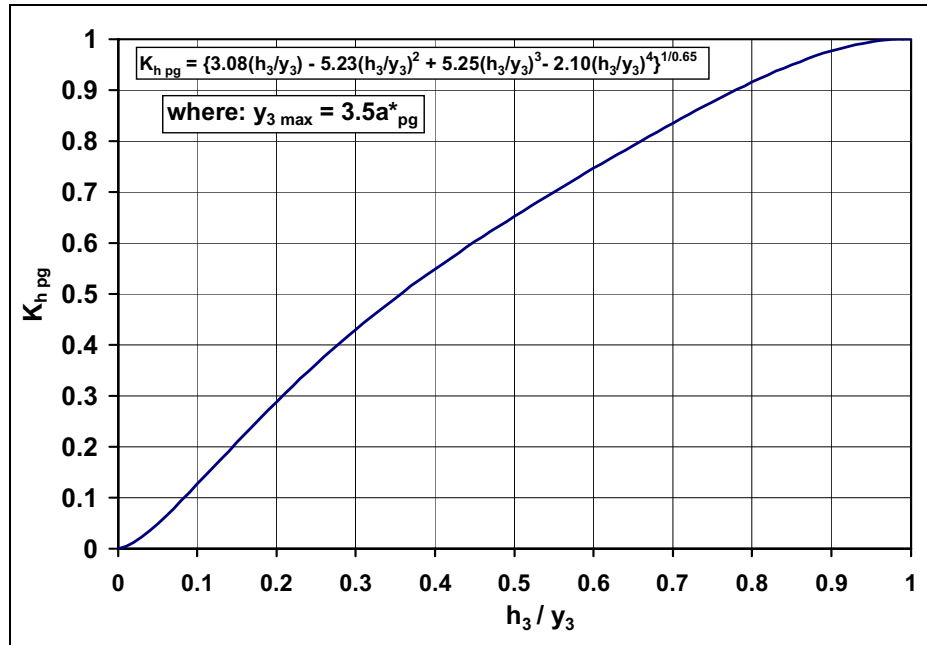

Figure 9. Pile group height adjustment factor (Sheppard, 2001).

The guidelines described in this section can be used to compute scour for a simple full depth pile group in which case the first two components will be zero and the pile group height factor will be 1.0. Engineering judgment must be used if debris is considered a factor in which case it would be logical to treat the pile group and debris as a vertical extension of the pile cap and to compute scour using the case 2 pile cap procedure described previously.

In cases of complex pile configurations where costs are a major concern, where significant savings are anticipated, and/or for major bridge crossings, physical model studies are still the best guide. Nevertheless, the guidelines described in this section provide a first estimate and a good indication of what can be anticipated from a physical model study.

In many complex piers, the pile groups have a different number of piles in a row or column, the spacing between piles is not uniform, and the widths of the piles may not all be the same. An estimate of the scour depth can be obtained using the methods and equations in this section. However, a physical model study should be conducted to determine scour depths for the final design. For guidance in the use of physical modeling see HEC-23 (Lagasse et al, 2001) and River Engineering for Highway Encroachments (Richardson et al, 2001).

## CONCLUSION

- Equations and methods are given for the calculation of local scour for complex piers. Complex piers are piers where scour could be caused by two or three substructural elements. These elements are the pier stem, the pile cap or footing, and the pile group.



2. A physical model study of complex piers, generally, will reduce uncertainty, increase the safety of the design, and reduce cost.

## LITERATURE CITED

- Johnson, P.A. and E.F. Torrico, 1994, "Scour Around Wide Piers in Shallow Water," Transportation Research Board Record 1471, Transportation Research Board, Washington, D.C.
- Jones, J.S., 1983, "Comparison of Prediction Equations for Bridge Pier and Abutment Scour," Transportation Research Record 950, Second Bridge Engineering Conference, Vol. 2, Transportation Research Board, Washington, D.C.
- Jones, J.S., 1989, "Laboratory Studies of the Effects of Footings and Pile Groups on Bridge Pier Scour," U.S. Interagency Sedimentation Committee Bridge Scour Symposium, U.S. Department of Transportation, Washington, D.C.
- Jones, J.S. and D. M. Sheppard, 2000, "Local Scour at Complex Pier Geometries," Proc. of the ASCE 2000 Joint Conference on Water Resources Engineering and Water Resources Planning and Management, July 30 - August 2, Minneapolis, MN.
- Lagasse, P.F., J. D. Schall, and E.V. Richardson, 2001, "Stream Stability at Highway Structures," Hydraulic Engineering Circular No. 20, Third Edition, FHWA NHI 01-002, Federal Highway Administration, Washington, D.C.
- Lagasse, P.F., L.W. Zevenbergen, J. D. Schall, and P.E. Clopper, 2001, "Bridge Scour and Stream Instability Countermeasures," Hydraulic Engineering Circular No. 23, Second Edition, FHWA NHI 01-003, Federal Highway Administration, Washington, D.C.
- Mueller, D.S., 1996, "Local Scour at Bridge Piers in Nonuniform Sediment Under Dynamic Conditions," Ph.D Dissertation, Colorado State University, Fort Collins, CO.
- Mueller, D.S. and J.S. Jones, 1999, "Evaluation of Recent Field and Laboratory Research on Scour at Bridge Piers in Coarse Bed Materials, ASCE 1999 Compendium, Stream Stability and Scour at Highway Bridges, Richardson and Lagasse (eds.), Reston, VA.
- Richardson, E.V., Karaki, S., Mahmoud, K., Simons, D.B., and Stevens, M.A., 1975, "Highways in the River Environment." Federal Highway Administration, U. S. Department of Transportation, reprinted July, 1983, Washington, D.C..
- Richardson, E.V. and P.F. Lagasse (eds.), 1999, "Stream Stability and Scour at Highway Bridge - Compendium of Papers, ASCE Water Resources Engineering Conferences 1991-1998," American Society of Civil Engineers, Reston, VA.
- Richardson, E.V., S. R. Davis, and P.F. Lagasse, 2001, "Evaluating Scour at Bridges," Hydraulic Engineering Circular No. 18 (HEC 18), Fourth Edition, FHWA NHI 01-001, Federal Highway Administration, Washington, D.C.
- Richardson, E.V., D. B. Simons, and P.F. Lagasse, 2001, "River Engineering for Highway in Encroachments," FHWA NHI 01-004, Federal Highway Administration, Hydraulic Series No. 6, Washington, D.C.
- Salim, M. and J. S. Jones, 1995, "Effects of Exposed Pile Foundations on Local Pier Scour,"

ASCE Water Resources Engineering, Reston, VA

- Salim, M. and J. S. Jones, 1996, "Scour Around Exposed Pile Foundations," ASCE North American and Water and Environment Congress, Reston, VA
- Salim, M and J. S. Jones, 1999, "Scour Around Exposed Pile Foundations," ASCE 1999 Compendium, Stream Stability and Scour at Highway Bridges, Richardson and Lagasse (eds.), Reston, VA.
- Smith, W.L., 1999, "Local Structure-Induced Sediment Scour at Pile Groups," M.S. Thesis, University of Florida, Gainesville, FL.
- Sheppard, D. M., 2001, "A Methodology for Predicting Local Scour Depths Near Bridge Piers with Complex Geometry's," C. E. Paper, University of Florida, Gainesville, FL.
- U.S. Department of Transportation, Federal Highway Administration, 1988, "Scour at Bridges," Technical Advisory T5140.20, updated by Technical Advisory T5140.23, October 28, 1991, "Evaluating Scour at Bridges," Washington, D.C.
- U.S. Department of Transportation, 1988, "Interim Procedures for Evaluating Scour at Bridges," Federal Highway Administration, Washington, D.C.